

## DISPOSAL

### HINT:

When scrapping vehicle equipped with an SRS or disposing of a front passenger airbag assembly, always first deploy the airbag in accordance with the procedure described below. If any abnormality occurs with the airbag deployment, contact the SERVICE DEPT. of TOYOTA MOTOR SALES, U.S.A., INC.

### CAUTION:

- **Never dispose of a front passenger airbag assembly which has an undeployed airbag.**
- **The airbag produces a sizeable exploding sound when it deploys, so perform the operation out-of-doors and where it will not disturb nearby residents.**



- **When deploying the airbag, always use the specified SST (SRS Airbag Deployment Tool). Perform the operation in a place away from electrical noise.**  
SST 09082-00700
- **When deploying an airbag, perform the operation at least 10 m (33 ft) away from the front passenger airbag assembly.**
- **The front passenger airbag assembly is very hot when the airbag is deployed, so leave it alone for at least 30 minutes after deployment.**
- **Use gloves and safety glasses when handling a front passenger airbag assembly with the deployed airbag.**
- **Always wash your hands with water after completing the operation.**
- **Do not apply water, etc. to a front passenger airbag assembly with the deployed airbag.**

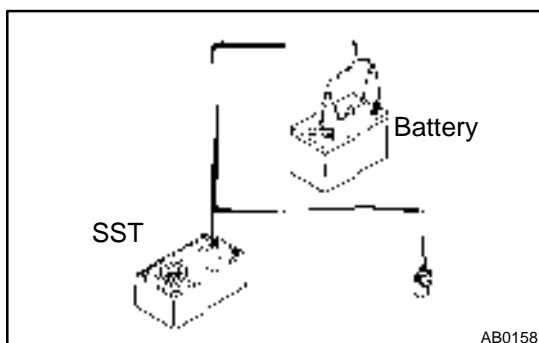

### 1. AIRBAG DEPLOYMENT WHEN SCRAPPING VEHICLE

#### HINT:

Have a battery ready as the power source to deploy the airbag.

- (a) Check functioning of the SST (See step 1-(a) on page [RS-15](#)).

SST 09082-00700

- (b) Remove the glove compartment door.

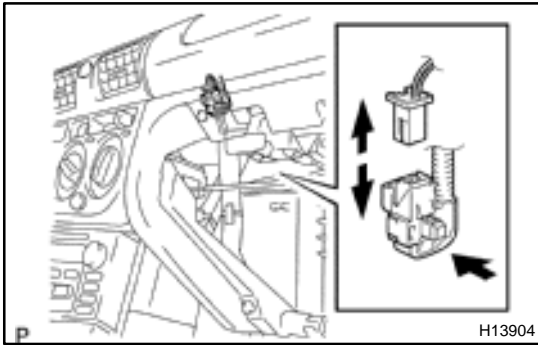

(c) Disconnect the airbag connector.

**NOTICE:**

**When handling the airbag connector, take care not to damage the airbag wire harness.**

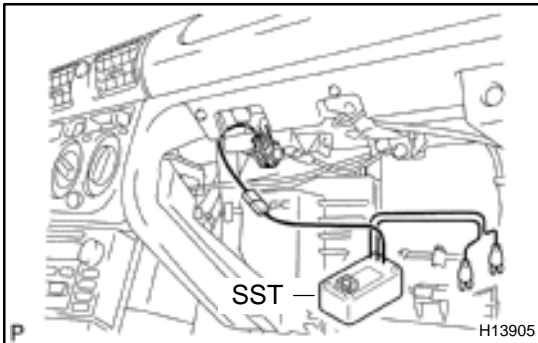

(d) Install the SST.

- (1) Connect the connectors of the 2 SST to the front passenger airbag assembly connector.

SST 09082-00700, 09082-00760

**NOTICE:**

**To avoid damaging the SST connector and wire harness, do not lock the secondary lock of the twin lock.**

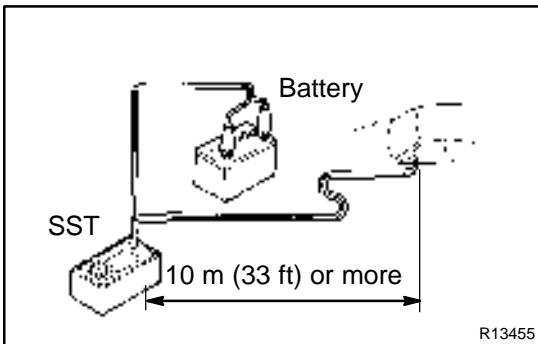

- (2) Move the SST at least 10 m (33 ft) away from the front of the vehicle.

- (3) Close all the doors and windows of the vehicle.

**NOTICE:**

**Take care not to damage the SST wire harness.**

- (4) Connect the SST red clip to the battery positive (+) terminal and the black clip to the negative (-) terminal.

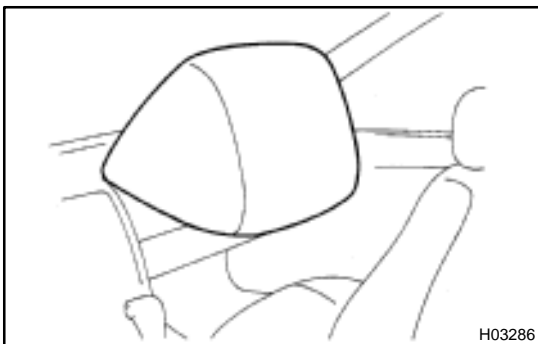

(e) Deploy the airbag.

- (1) Check that no one is inside the vehicle or within 10 m (33 ft) area around the vehicle.

- (2) Press the SST activation switch and deploy the airbag.

**CAUTION:**

- The front passenger airbag assembly is very hot when the airbag is deployed, so leave it alone for at least 30 minutes after deployment.
- Use gloves and safety glasses when handling the front passenger airbag assembly with the deployed airbag.
- Always wash your hands with water after completing the operation.
- Do not apply water, etc. to the front passenger airbag assembly with the deployed airbag.
- When scrapping a vehicle, deploy the airbag and scrap the vehicle with the front passenger airbag assembly still installed.
- When moving a vehicle for scrapping which has the front passenger airbag assembly with the deployed airbag, use gloves and safety glasses.

**HINT:**

The airbag deploys simultaneously as the LED of the SST activation switch lights up.

## 2. DEPLOYMENT WHEN DISPOSING OF FRONT PASSENGER AIRBAG ASSEMBLY ONLY

**NOTICE:**

- When disposing of the front passenger airbag assembly only, never use the customer's vehicle to deploy the airbag.
- Be sure to follow the procedure given below when deploying the airbag.

**HINT:**

Have a battery ready as the power source to deploy the airbag.

- (a) Remove the front passenger airbag assembly (See page [RS-26](#)).

**CAUTION:**

- When removing the front passenger airbag assembly, work must be started 90 seconds after the ignition switch is turned to the "LOCK" position and the negative (-) terminal cable is disconnected from the battery.
- When storing the front passenger airbag assembly, keep the upper surface of the airbag deployment side facing upward.

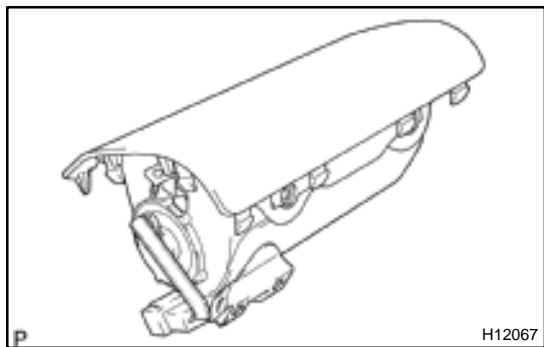

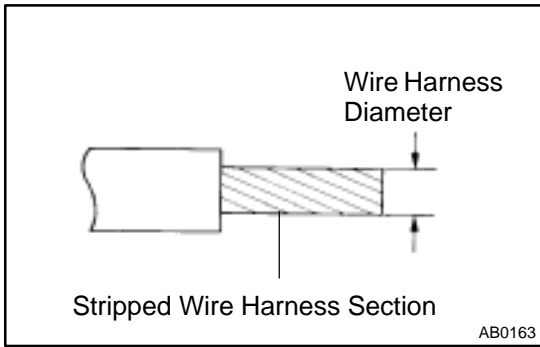

- (b) Using a service-purpose wire harness, tie down the front passenger airbag assembly to the tire.  
**Wire harness: Stripped wire harness section 1.25 mm<sup>2</sup> or more (0.0019 in.<sup>2</sup> or more)**

**CAUTION:**

If the front passenger airbag assembly is tied down with too thin wire harness, it may snap. This is highly dangerous. Always use a wire harness which is at least 1.25 mm<sup>2</sup> (0.0019 in.<sup>2</sup>).

**HINT:**

To calculate the square of the stripped wire harness section:

**Square = 3.14 x (Diameter)<sup>2</sup> divided by 4**

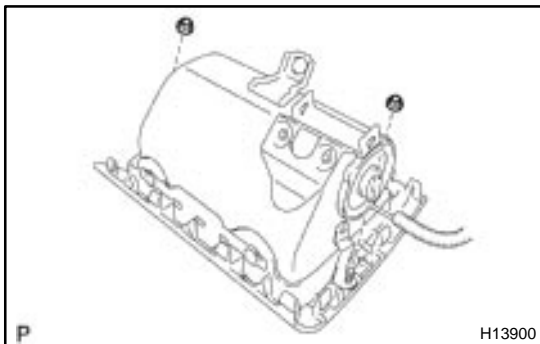

- (1) Install the front passenger airbag assembly with the 2 nuts.

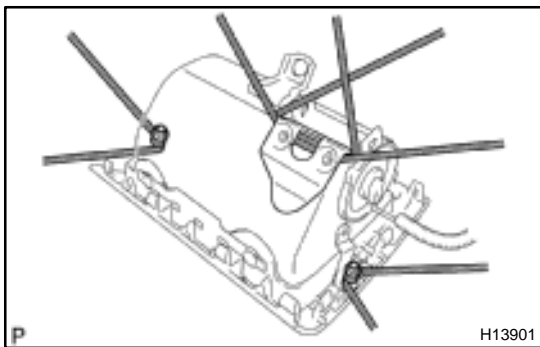

- (2) Wind the wire harness around the bolts, and pass the wire harness through the installation holes.

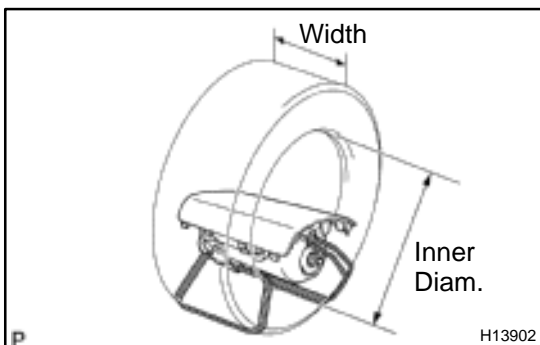

- (3) Position the front passenger airbag assembly inside the tire with the airbag deployment side facing inside.

**Tire size: Must exceed the following dimensions–**

**Width: 185 mm (7.28 in.)**

**Inner diameter: 360 mm (14.17 in.)**

**CAUTION:**

- Make sure that the wire harness is tight. It is very dangerous if loosen wire harness causes the front passenger airbag assembly to came free due to the shock from the airbag deploying.
- Always tie down the front passenger airbag assembly with the airbag deployment side facing inside.

**NOTICE:**

The tire will be marked by the airbag deployment, so when disposing of the airbag use a redundant tire.

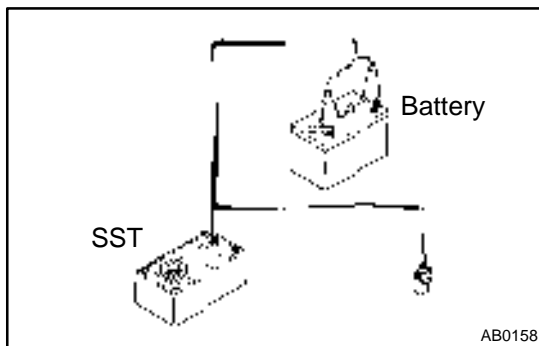

- (c) Check functioning of the SST (See step 1–(a) on page [RS-15](#)).  
SST 09082-00700

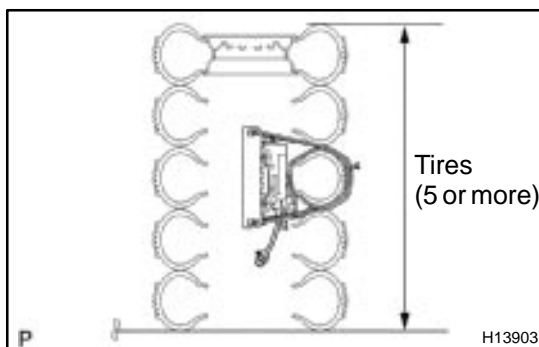

- (d) Place the tires.
- (1) Place at least 2 tires under the tire to which the front passenger airbag assembly is tied.
  - (2) Place at least 2 tires over the tire to which the front passenger airbag assembly is tied. The top tire should have the wheel installed.

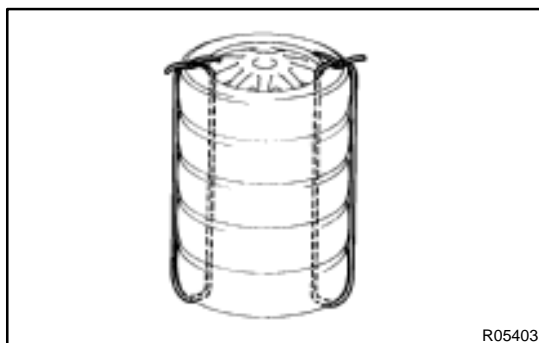

- (3) Tie the tires together with the 2 wire harnesses.

**CAUTION:**

Make sure that the wire harness is tight. It is very dangerous if loose wire harnesses cause the tires to came free due to the shock from the airbag deploying.

**HINT:**

Place the SST connector and wire harness inside tires. Provide at least 1 m (3 ft) of slack for the wire harness.

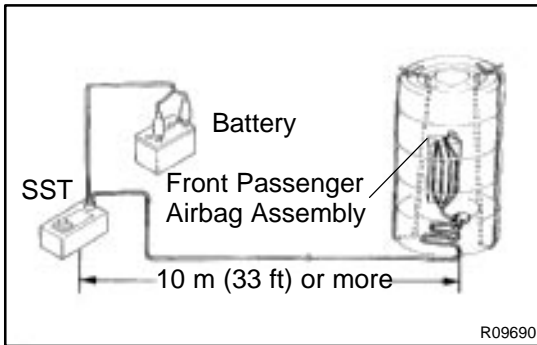

- (e) Install the SST.  
Connect the connectors of the 2 SST to the front passenger airbag assembly connector.  
SST 09082-00700, 09082-00760

**NOTICE:**

**To avoid damaging the SST connector and wire harness, do not lock the secondary lock of the twin lock. Also, remove some slack for the SST wire harness inside the tires.**

- (f) Deploy the airbag.
- (1) Connect the SST red clip to the battery positive (+) terminal and the black clip to the battery negative (-) terminal.
  - (2) Check that no one is within 10 m (33 ft) area around the tire which the front passenger airbag assembly is tied to.
  - (3) Press the SST activation switch and deploy the airbag.

**HINT:**

The airbag deploys simultaneously as the LED of the SST activation switch lights up.

- (g) Dispose of the front passenger airbag assembly.

**CAUTION:**

- **The front passenger airbag assembly is very hot when the airbag is deployed, so leave it alone for at least 30 minutes after deployment.**
  - **Use gloves and safety glasses when handling a front passenger airbag assembly with the deployed airbag.**
  - **Always wash your hands with water after completing the operation.**
  - **Do not apply water, etc. to a front passenger airbag assembly with the deployed airbag.**
- (1) Remove the front passenger airbag assembly from the tire.
  - (2) Place the front passenger airbag assembly in a vinyl bag, tie the end tightly and dispose of it in the same way as other parts disposal.



### 3. DEPLOYMENT WHEN DISPOSING OF FRONT PASSENGER AIRBAG ASSEMBLY WITH AIRBAG DEPLOYED IN COLLISION

Dispose of the front passenger airbag assembly.



**CAUTION:**

- **The front passenger airbag assembly is very hot when the airbag is deployed, so leave it alone for at least 30 minutes after deployment.**
- **Use gloves and safety glasses when handling a front passenger airbag assembly with the deployed airbag.**
- **Always wash your hands with water after completing the operation.**
- **Do not apply water, etc. to a front passenger airbag assembly with the deployed airbag.**
  - (1) Remove the front passenger airbag assembly from the instrument panel (See page [RS-26](#)).
  - (2) Place the front passenger airbag assembly in a vinyl bag, tie the end tightly and dispose of it in the same way so as othe parts disposal.